

FCP Solar SOX Street Lights - Double Arm

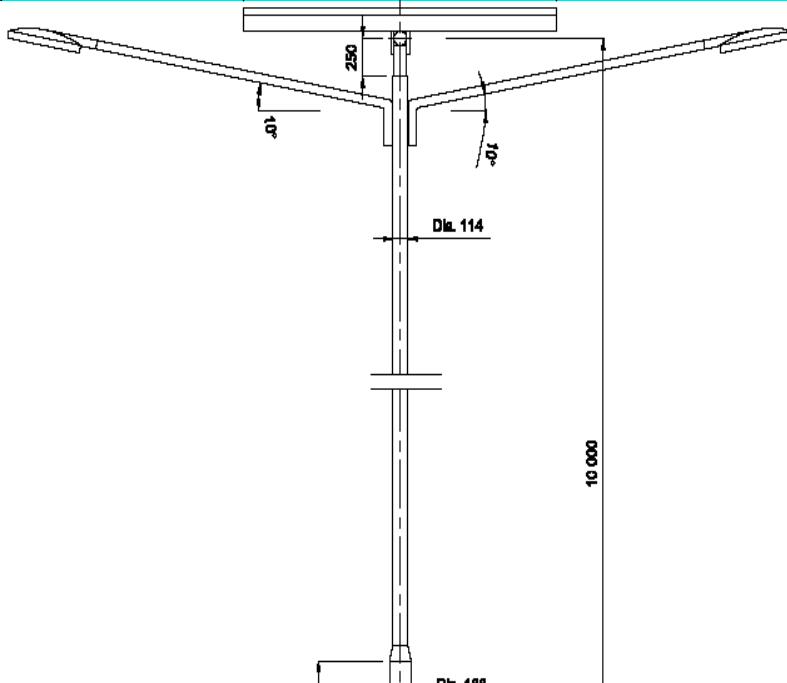

LAMP STYLES



55W Low Pressure Sodium - Double Arm

SYSTEM COMPONENTS

- 2 x 24V 55W Low Pressure Sodium lamps
- 1 x Electronic Ballast
- 1 x 24V 280W polycrystalline solar panels, with junction boxes
- 1 x 24V 15A solar charge controller with automatic day/night function
- 2 x 12V 150AH deep cycle maintenance-free batteries (2 days autonomy)
- 1 x Battery and controller box
- Lot—Interconnection cables
- 1 x 10m steel pole (painted) with arms for lamps

SOX FEATURES

- Each 55W SOX lamp giving— 8100 lm (lamp flux)
- Colour temperature: 1800 K
- Lifetime of LED— about 16,000 hrs

QUALITY

FORTUNE CP's solar street light systems use components with International Standards such as ISO 9001:2000, CE, IEC, TUV and others. The systems are suitable for supply to Europe, Americas, Africa and Asia.